



ESP Safety's Model **SGOES** Gas Detector measures the concentration of hydrocarbon gases present in the monitored environment. The **SGOES** is configured to report alarms when the gas concentrations in the environment reach the two independently programmable levels, expressed as a percentage of the lower explosive limit (LEL) in air. As determined by application requirements, the **SGOES** is factory calibrated with one of eight hydrocarbon-based gases (typically methane or propane). Conversion factors are used to correct for gases other than the factory calibration gas.

The **SGOES** sensor detects and quantifies the presence of hydrocarbons by measuring their absorption of infrared light (IR). Because the device does not depend on the presence of oxygen in a mixture of gases, it can function effectively in environments where other sensor technologies cannot. Moreover, it is not sensitive to gases such as nitrogen, oxygen, carbonic acid, ammonia, and hydrogen sulfide, that may adversely affect other types of sensors. This makes the **SGOES** an excellent choice for environments where non-hydrocarbon gases are present and where monitoring of hydrocarbons like methane and propane is required.

The explosion-proof design of **SGOES** makes it ideal for use in hazardous environments such as:

- Oil and gas facilities
- Refineries
- Pipelines
- Pumping stations
- Tank farms
- Loading racks

SGOES is FM-certified for use in potentially explosive gas/vapor environments in compliance with FM3615 and CSA-C22.2 No 30 standards for explosion proof protection. In addition, it meets CSA standard E60079-1 for flameproof protection, and ANSI/ISA standard 12.13.01-2000 for performance of combustible gas detectors.

The **SGOES** gas detector is typically used as an indicating device in fire and gas (F&G) detection and suppression systems as well as emergency shutdown (ESD) systems.

The rugged **SGOES** design allows it to be used in harsh environments. It will operate from -76°F to +185°F (-60°C to +85°C) at relative humidity up to 95%.

Features and Benefits

- High sensitivity to all hydrocarbon gases/vapors for maximum property protection and personal safety
- Open path optical sensor - no physical contact between sensor and environment
- IR optical path obstruction monitoring (dust, paint, etc.) provides maintenance alerts
- Heated optics, secondary heater function helps to prevent condensation problems
- Low power (<4.5W) operation for cost savings
- Versatile indoor/outdoor installation
- Industry standard analog, digital, and relay outputs are used for remote alarm and fault indications
- Resistance to vibration ensures reliability and durability
- Operates effectively in fog and high humidity
- Wide operating temperature range provides flexibility and reliability
- Tri-color status LED on the device is easily viewable for a visual report of the device's operating status

Applications

- Drilling and production platforms
- Shipping tankers, freighters, and other vessels
- Fuel loading facilities
- Refineries, bulk terminals, and tank farms
- LNG/LPG processing and storage facilities
- Compressor stations and pipeline facilities
- Petrochemical, paint, and fertilizer plants
- Power plants and gas turbine facilities
- Transportation facilities (airports and subways)
- Oil and gas fired boilers / furnaces
- Environmental regulation monitoring

ELECTRICAL CHARACTERISTICS

Voltage	18 to 32 VDC
Power	2 W, standby 4.5 W, during alarm 7.9 W, heater on maximum
Outputs	4-20mA, analog (0 to 100% LEL) two alarm relays (isolated, dry contact type) with programmable thresholds fault relay indicating optical path obstruction RS-485 Modbus RTU, HART, Ethernet
Recommended Wiring	16 AWG (1.5mm) for 4000ft (1200m) max

PERFORMANCE

Gases	methane, propane, butane, pentane, hexane, isobutane, cyclopentane, ethanol (The target gas is factory configurable according to customer request.)
Range	0 to 100% LEL (lower explosive level – in air)
Accuracy	±2% LEL, for 0 to 100% LEL
Humidity	Up to 95%, non-condensing (withstands up to 100% RH for short periods)
Response Time (for 100% LEL Methane)	50% full scale < 1.5 seconds 90% full scale < 2.0 seconds
Operating Temperature	-76°F to +185°F (-60°C to +85°C)
Response Time (for 100% LEL Methane)	-76°F to +194°F (-60°C to +90°C)
Storage Temperature	-58°F to +125°F (-50°C to +50°C)
Ingress Protection	IP66
SIL Rating	SIL 2
Warranty	5 Years

CALIBRATION

Factory calibrated at 0%, 20%, 50%, and 95% LEL with methane or propane. Calibration with NIST traceable calibration gas is optional.

CONFIGURATION OPTIONS

Standard Gas options:	<ul style="list-style-type: none"> • Methane • Propane • Butane • Pentane 	<ul style="list-style-type: none"> • Hexane • Isobutane • Cyclopentane • Ethanol
Custom Gas configuration options:	<ul style="list-style-type: none"> • Volatile Organic Compounds (VOC) • Optional calibration with gas mixtures directly traceable to NIST standard reference materials. 	



SGOES Detector

Field Communicator
(sold separately)

Dimensions
in inches (centimeters)

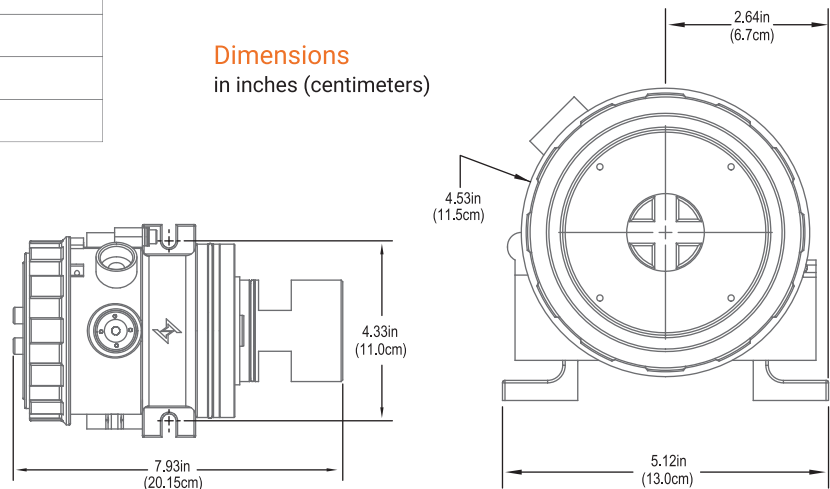

MECHANICAL CHARACTERISTICS

Material	316L Stainless Steel
Diameter	5.5" (14 cm)
Length	11.5" (29 cm)
Weight	14.3lbs (6.5 kg)
Conduct Entry	3/4" NPT

CERTIFICATIONS

Class I, Division 1
Groups B, C & D
T4 Ta = -40°F to +167°F
(-40°C to +75°C)
IP66

Class I, Division 1
Groups B, C & D
T4 Ta = -40°F to +167°F
(-40°C to +75°C)
IP66

Ex d IIC T4
-40°F to +185°F
(-40°C to +85°C)
CE Mark for EMC (TUV)
CE Mark for IECEx
IP66

Ex d IIC T4
-40°F to +185°F
(-40°C to +85°C)
IP66

Class I, Division 1
Groups B, C & D
T4 Ta = -40°F to +167°F
(-40°C to +75°C)
IP66