

ESP Safety's Model **IPES-IR/UV** Flame Detector provides superior sensitivity for fires from oil and petrochemical products. It is also indicated for a wide range of other fire types including metal fires.

IPES-IR/UV's advanced detection technology includes optical filters configured for maximum sensitivity to radiation produced by flame or fire and ensures rapid flame recognition and alarm signaling. Upon fire recognition within its field of view, the **IPES-IR/UV** signals a change in state from normal operation to fire in any OEM or proprietary alarm and response system.

In addition, via integrated ultraviolet (**UV**) and infrared (**IR**) sensors, the **IPES-IR/UV** monitors in specific regions of both spectral ranges. In the infrared spectrum, the device is configured for sensitivity to wavelengths in the range of 3 -5 microns, allowing optimal sensitivity to combustible gas fires while rejecting false signals from incandescent lamps, sunlight and hot objects. For ultraviolet (UV) radiation, the device is configured for sensitivity in the range of 180 to 250 nanometers, making the sensor "blind" to sunlight and radiation from heated objects but still able to "see" the UV radiation emitted by a flame. With these settings, the **IPES-IR/UV** detects and alarms for only those characteristic wavelength emissions from the UV and IR spectrum that indicate actual flame or fire.

The combination of multiple sensors and wavelength range settings makes the **IPES-IR/UV** an excellent choice for elimination of false positive indicators caused by non-flame sources of radiation such as artificial lighting, direct and indirect sunlight, lightning, arc welding and metal grinding.

While operating, the **IPES-IR/UV** generates detector-status information via:

- **A standard RS-485 communication channel under protocol Modbus RTU**
- **4-20 mA analog output**
- **Relay outputs**
- **HART Communication**



The **IPES-IR/UV** is constructed in an explosion-proof housing for use in hazardous (classified) locations and meets the industry certifications and requirements of Class I, Division 1, Group B, C & D, T5.

Features and Benefits

- Power consumption of <3W means low power costs, protection against surges
- Digital, analog and relay outputs provide reliable status information across a range of communication formats
- Automatic and manual self-tests ensure system integrity and correct operation
- Continuous monitoring of the optical path for obstruction or reduced transmission affords maximum reliability
- Industry standard for remote alarm and fault indication
- Combines both IR sensor configuration and UV sensor configuration
- Color status LED
- Explosion-proof package allows for hazardous environment operation
- Heated optics, secondary heater function helps to prevent condensation problems

Applications

- Drilling and production platforms
- Shipping tankers, freighters, and other vessels
- Fuel loading facilities
- Refineries, bulk terminals, and tank farms
- LNG/LPG processing and storage facilities
- Compressor stations and pipeline facilities
- Petrochemical, paint, and fertilizer plants
- Power plants and gas turbine facilities
- Transportation facilities (airports and subways)
- Oil and gas fired boilers / furnaces
- Aircraft hangars

ELECTRICAL CHARACTERISTICS

Operating Voltage	18 to 32 VDC	
Power consumption	<2.0 W, standby <3.0 W, during alarm <5.0 W, self test <7.5 W, maximum with heated window & alarm	
Analog Outputs	Analog signal Fault signal Ready signal Fire signal Test Mode	4-20 mA 2 mA ± 0.1 mA 4 mA ± 0.1 mA 20 mA ± 0.1 mA 8 mA ± 0.1 mA
Digital Outputs	RS 485, Modbus RTU, Profibus	
Relay Contact	Fire Alarm: - normally open/normally closed (NO/NC) user selectable - latching / non-latching Fault: - normally open/normally closed (NO/NC) user selectable	
HART interface	by request	
Operating Temperature	-40°F to +185°F (-40°C to +85°C)	
Extended Operating Temperature (By Request)	-75°F to +255°F (-60°C to +125°C)	
Storage Temperature	-76°F to +185°F (-60°C to +85°C)	
Humidity	Up to 95 % Relative humidity, (withstands up to 100% RH for short periods)	
Wiring	14 AWG (2.08 mm ²) or 16 AWG (1.31 mm ²) Shielded cable is recommended	

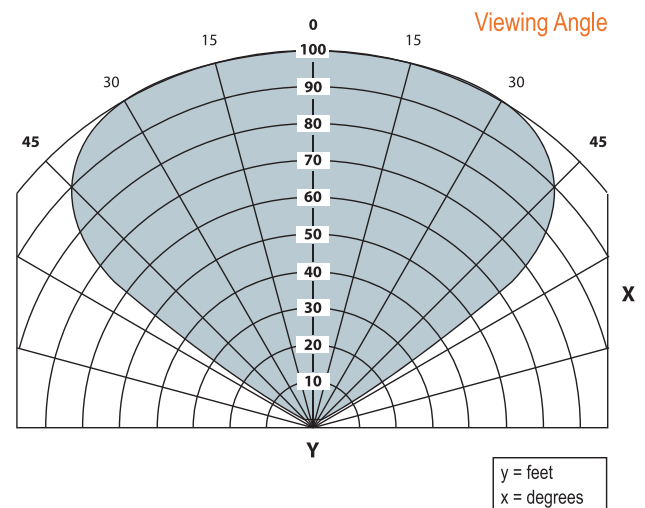
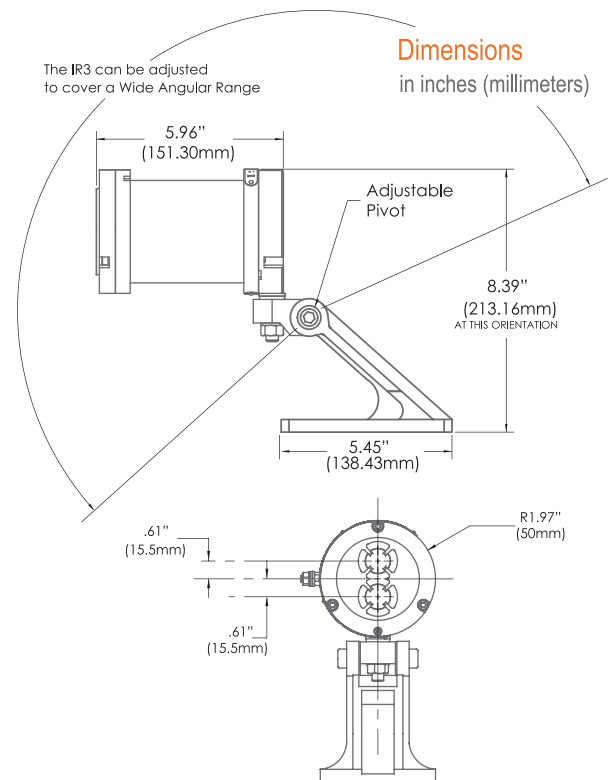

FIELD OF VIEW

The detector has a 90° field of view (horizontal) with the highest sensitivity lying along the central axis.

* 120° field of view version available by request.

MECHANICAL CHARACTERISTICS

Material	Aluminum or 316 Stainless Steel
Cable Entry	3/4" NPT
Weight	Aluminum: 5.5 lbs (2.5 kg) Stainless Steel: 11 lbs (5.0 kg)
Warranty	5 years

CERTIFICATIONS

Class I, Division 1 Groups B, C & D T5 Ta = -40°F to +167°F (-40°C to +75°C) IP66	Ex d IIC T5 -40°F to +185°F (-40°C to +85°C)	Class I, Division 1 Groups B, C & D T5 Ta = -40°F to +167°F (-40°C to +75°C) IP66	Ex d IIC T5 -40°F to +185°F (-40°C to +85°C) IP66
---	--	---	--

RESPONSE TIME *Very High Sensitivity*

Fuel	Size	Distance Feet (M)	Typical Response Time (Sec.)
n-Heptane	1 ft x 1 ft	100 (30)	5.0
Methanol	1 ft x 1 ft	85 (26)	4.9
JP5	2 ft x 2 ft	100 (30)	5.0