

The state-of-the-art multi-spectral infrared technology of ESP Safety's Model **IPES-IR3** Flame Detector affords the highest sensitivity in detecting flames from combustible vapors gases within a wide field of view. It is preferred where UV in other detectors may be a problem with false signal triggers.

**IPES-IR3**'s advanced detection technology ensures rapid flame recognition and alarm signaling. In addition, **IPES-IR3**'s selective, multi-spectral technology virtually eliminates false alarms. It ignores false triggers from sources such as direct or indirect sunlight, arc welder flash, resistive heaters, fluorescent, halogen, and incandescent light.

**IPES-IR3** sends an alarm only when data from three different IR wavelengths agree that a flame or fire is present in the field of view. Upon confirmation of flame or fire, the **IPES-IR3** transfers alarm signals to receiving control devices located in control and operations rooms and to fire alarms and burglar/fire alarm systems. While operating, the **IPES-IR3** transmits detector-status information via:

- 4-20 current loop w/ HART
- A standard RS-485 communication channel under protocol Modbus RTU
- Relay outputs

The **IPES-IR3** Flame Detector is constructed with an explosion-proof housing for use in hazardous (classified) locations. It meets the certifications and requirements of Class I, Division 1, Group B, C & D, T4.



## Features and Benefits

- Multi-spectral IR detection provides the highest level of flame and fire sensitivity.
- Multi-spectral IR detection provides optimal rejection of false alarms.
- Power-on self-test and frequent sensor self-test ensure system integrity and correct operation.
- Heated optics, secondary heater function helps to prevent condensation problems.
- Explosion-proof package allows for hazardous environment operation.
- Tri-color status LED on the device is easily viewable for a visual report of the device's operating status.
- Continuous monitoring of the optical path for obstruction or reduced transmission affords maximum reliability.
- Power consumption of <3W means low power costs, protection against surges.
- Digital, analog and relay outputs provide reliable status information across a range of communication formats.
- Industry standard for remote alarm and fault indication ensure reliability and consistency.
- Extended detection range provides a greater area of protection.
- 5-year warranty – long, reliable product life; low cost to operate over time.

## Applications

- Drilling and production platforms
- Shipping tankers, freighters, and other vessels
- Fuel loading facilities
- Refineries, bulk terminals, and tank farms
- LNG/LPG processing and storage facilities
- Compressor stations and pipeline facilities
- Petrochemical, paint, and fertilizer plants
- Power plants and gas turbine facilities
- Transportation facilities (airports and subways)
- Oil and gas fired boilers / furnaces
- Aircraft hangars

### ELECTRICAL CHARACTERISTICS

Operating Voltage	18 to 32 VDC	
Power consumption	<2 W, standby <3 W, during alarm <7.5 W, with heater on maximum	
Analog Outputs	HART 4-20mA Analog signal Fault signal Ready signal Fire signal Test Mode	Current 2 mA ± 0.1 mA 4 mA ± 0.1 mA 18 mA ± 0.1 mA 8 mA ± 0.1 mA
Digital Outputs	RS 485, Modbus RTU, Profibus	
Relay Contact	Fire Alarm: <ul style="list-style-type: none"> <li>- normally open relay</li> <li>- closed on fire detection</li> <li>- latching or non-latching</li> </ul>	
	Fault: <ul style="list-style-type: none"> <li>- normally closed relay</li> <li>- open on fault detection</li> </ul>	
Operating Temperature	-40°F to +185°F (-40°C to +85°C)	
Extended Operating Temperature (By Request)	-75°F to +255°F (-60°C to +125°C)	
Storage Temperature	-76°F to +185°F (-60°C to +85°C)	
Humidity	Up to 95 % Relative humidity, non-condensing (withstands up to 100% RH for short periods)	
Wiring	14 AWG (2.08 mm <sup>2</sup> ) or 16 AWG (1.31 mm <sup>2</sup> ) Shielded cable is recommended	
SIL Rating	SIL 3	
Ingress Protection	IP66	

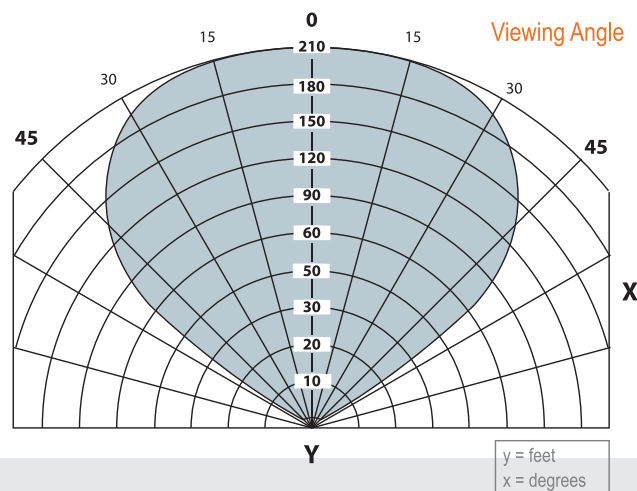
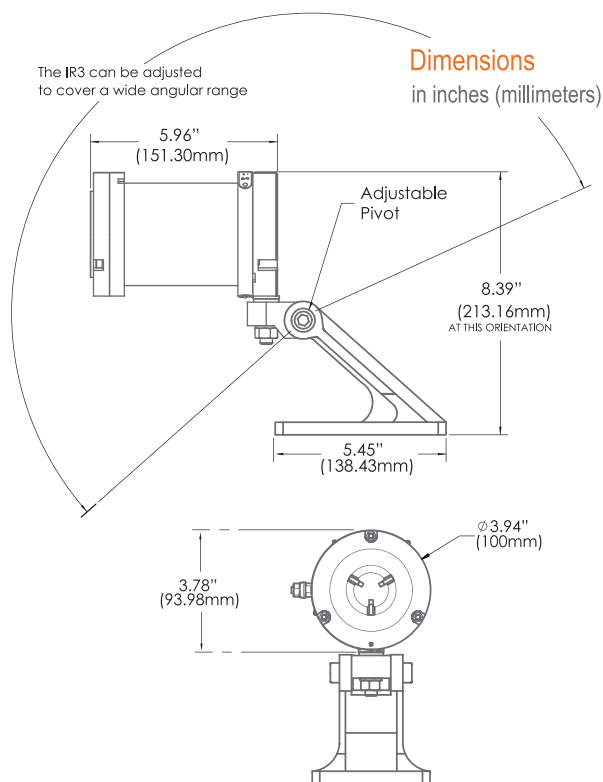

### MECHANICAL CHARACTERISTICS

Material	Aluminum and 316 Stainless Steel
Cable Entry	3/4" NPT
Weight	11 lbs (5.0 kg)
Warranty	5 years

### FIELD OF VIEW

Fuel	Horizontal (left)	Horizontal (right)	Vertical (up)	Vertical (down)	Min. Distance Feet (down)	Avg Time
n-Heptane	50°	50°	50°	50°	56.1 (17.1)	3 sec.
Methanol	50°	50°	50°	50°	41.0 (12.5)	3 sec.
JP5	50°	50°	50°	50°	82.0 (25.0)	3 sec.

### CERTIFICATIONS

Class I, Division 1 Groups B, C & D T4 Ta = -40°F to +167°F (-40°C to +75°C) IP66	Ex d IIC T4 -40°F to +185°F (-40°C to +85°C) CE Mark for EMC (TUV) CE Mark for IECEx IP66	Class I, Division 1 Groups B, C & D T4 Ta = -40°F to +167°F (-40°C to +75°C) IP66	Ex d IIC T4 -40°F to +185°F (-40°C to +85°C) IP66
---	--	---	--

### RESPONSE TIME

Fuel	Size	Distance Feet (M)	Typical Response Feet (M) Time (Sec.)
n-Heptane	1 ft x 1 ft	210 (64.0)	5.0
Methanol	1 ft x 1 ft	150 (45.7)	7.0
JP5	2 ft x 2 ft	210 (64.0)	4.5