

Forklift Spot Light Projector Datasheet



Overview:

SafetyCast™ Hazard Illumination Forklift Spot Light provides visual warning to pedestrians and vehicles in accident prone areas, or areas where pedestrians share floor space with mobile industrial handling equipment, such as warehouses, dock and loading areas or any industrial workplace pedestrians. This solution is extremely effective in noisy areas where audible alarms can be drowned out, or where multiple alarms may confuse the pedestrian. The product is weatherproof, thus ideal for indoor and outdoor use.

Key Features:

- Easy to install on any forklift in minutes
- Adjustable mounting bracket allows for easy positioning of the beam on the floor
- High visibility illuminated projections provide the pedestrian with clear knowledge of their proximity to moving equipment
- Weatherproof and ideal for indoor/outdoor use
- Run off 10-80VDC
- Long operating life of 30,000+ hrs

Specifications:

Lamp Details

| | |
|----------------------------------|---------------------------|
| Type of Light Source: | High Performance LED |
| Rated Power: | 6W |
| Light Source Life (MTTF): | 30,000 hours at 25°C/77°F |

Optical

| | |
|------------------------------|-----------|
| Light Colour: | Red, Blue |
| Projection Type: | Spot |
| Projection Fan Angle: | 6° |

| | |
|--------------------------------|-----------------------------|
| Temperature Range (°C): | -20 to 50 °C (-4 to 120 °F) |
| Operating Voltage: | 10-80V DC |
| IP Rating: | IP65 |
| Weight: | 1.4 Kg (3.08 lb) |

| | |
|---------------------------|-----------|
| Standard Warranty: | 12 months |
|---------------------------|-----------|

Forklift Spot Light Projector

Dimensions:

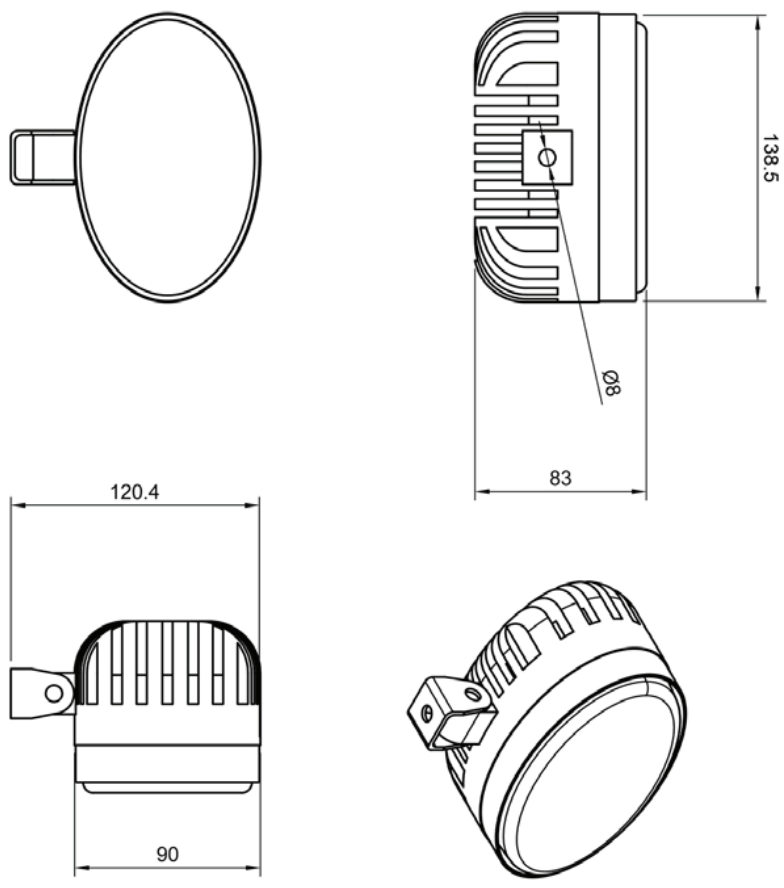



www.fsesafe.com

E&OE: Data included in this sheet may be subject to change without notice.
Please confirm critical specifications with our staff prior to ordering.