

SPX/SPZ **SPARTAN**

Bulkhead & Flood BL24 Range - Installation Guide

Zone 1 variant CML 13ATEX3007, IEC Ex CML14.0001 & CML21UKEX3099

Zone 2 variant CML 17ATEX4231, IEC Ex CML17.0135 & CML21UKEX4106

This installation guide provides instructions for installing the White-Light SPARTAN series of explosion protected bulkheads.

Text in italics is specific for emergency variants.

Overview

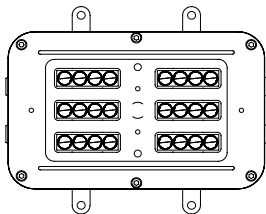

- 1 Safety Instructions
- 2 Installation
- 3 Maintenance
- 4 Technical Specification
- 5 Declaration of Conformity

Important information

The SPARTAN series of explosion protected bulkheads are specialist devices, certified for use in specific operating environments.

The units must be installed in accordance with these instructions, must be correctly certified for the specific operating environment and must be installed by suitably qualified personnel.

If you have any queries about the installation or the certification of the unit – please contact Raytec for immediate assistance and advice.

1. Safety instructions

1. Read this leaflet carefully before commencing to install the SPARTAN Bulkhead unit and retain it for future use. Installation can only be carried out by suitably qualified personnel.
2. Check the certification nameplate attached to the luminaire to ensure that the hazardous zone, mains supply, ambient temperature present and 'T' rating are suitable for the environment the unit is being installed in.
3. If the SPARTAN unit is to be installed in areas of high vibration, please consult with Raytec.
4. Externally the SPARTAN unit housing is constructed from marine grade aluminium, and toughened glass, stainless steel brackets/fasteners and silicone gaskets, internally there are many non metallic components. The end user must ensure that these materials are suitable for the environment the SPARTAN unit will be installed in; Zone 1 and Zone 2 Hazardous areas.
5. SPARTAN units are designed to withstand marine environments and are tested in accordance with IEC60068-2-52. However if the SPARTAN unit is to be installed in a very high corrosive environment such as **coastal** and **offshore** the following good practice should be followed:

During installing ensure there are no scratches, chips or defects in external paint surface that would allow ingress of water to bare aluminium. If so touch up with suitable paint

During installation apply an anti corrosive jointing compound to screw threads such as PSU cover and external earth points.

During installation ensure exterior surface of the product is not in direct contact with a dissimilar metal such as galvanised steel. If so fit a nylon barrier to prevent galvanic corrosion.

During maintenance regularly wash down external surface of fitting with clean, fresh water to remove any deposits of mineral salts on the exterior surface.

6. Check certification nameplate on side of bulkhead to ascertain type of threaded cable entry on the luminaire. Select suitably certified ATEX/IEC Ex/UKEX cable glands and stopper plugs, these must be parallel thread, have a minimum of 5 full thread engagement and be of a medium/fine tolerance to ISO965-1 and ISO965-3. The cable entry devices selected must maintain the IP rating of the luminaire
7. The incoming mains cable should not exceed a temperature rise of 24°C above the ambient conditions; select suitable cable.
8. When the unit is installed correctly and in accordance with these installation instructions it will not harm humans or animals
9. Before installing emergency luminaires please check the last charge date of the battery. This is shown on the external product packaging and also on the battery label, alternatively consult date shown on the declaration at the back of this leaflet. If the last charge date was in excess of 3 months (if stored at 5°C to 25°C) or 1 month (if stored outside this range) from date of installation, please consult Raytec document 0010-D-00001 Battery Handling Guide

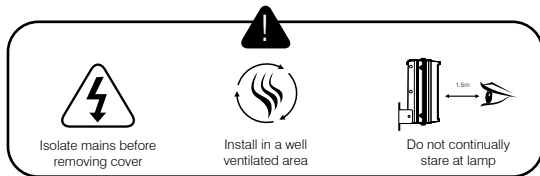

2. Installation

Mounting SPARTAN Bulkhead Unit

1. To meet the requirements of certification a **MINIMUM** of 2 fixing points must be used, the fixing points must be suitable for the conditions of use. Raytec recommend using M6 Marine Grade A4 Stainless Steel fixings (not supplied)

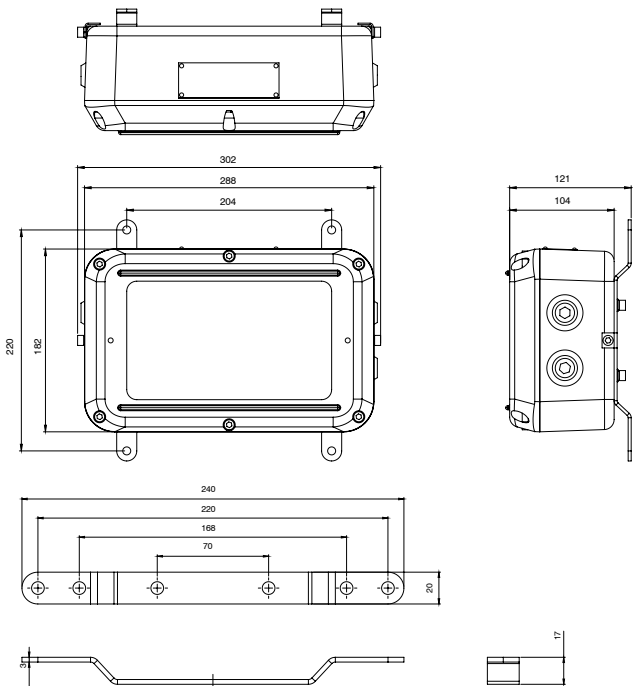

SPARTAN Flood BL24 Mounting Instructions

1. ATTACH 2-OFF L-BRACKET (ITEM 2) TO VACANT FIXING HOLES ON REAR OF BULKHEAD BODY, USING 4-OFF M6X12 SCREWS (ITEM 5) & M6 SPRING-WASHER (ITEM 6) AS SHOWN.

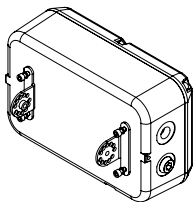

2. ALIGN STIRRUP BRACKET (ITEM 7) WITH L-BRACKETS, POSITION M8 FIBRE WASHER (ITEM 1) BETWEEN BOTH BRACKETS AND FIT M8 SCREW (ITEM 3) WITH M8 SPRING-WASHER (ITEM 4) TO BOTH SIDES OF STIRRUP AS SHOWN BELOW AND FULLY TIGHTEN.

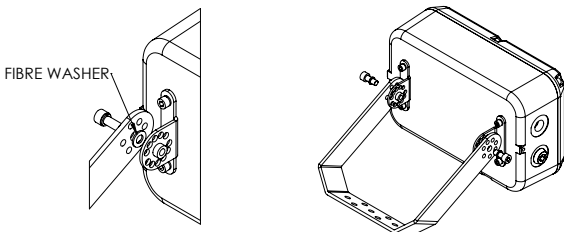

3. POSITION STIRRUP TO PREFERRED ANGLE AND SECURE USING REMAINING M6 SREW, SPRING-WASHER AND NUT (ITEM 9)

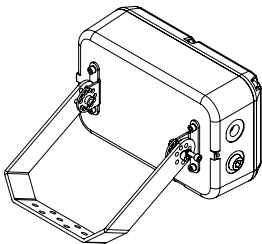

ITEM NO.	DESCRIPTION	QTY.
1	M8 FIBRE WASHER	2
2	L-BRACKET	2
3	M8X20 SOCKET CAP	2
4	M8 SPRING WASHER	2
5	M6X12 SOCKET CAP	4
6	M6 SPRING WASHER	5
7	STIRRUP BRACKET	1
8	M6X20 SOCKET CAP	1
9	M6 NUT St/Steel	1

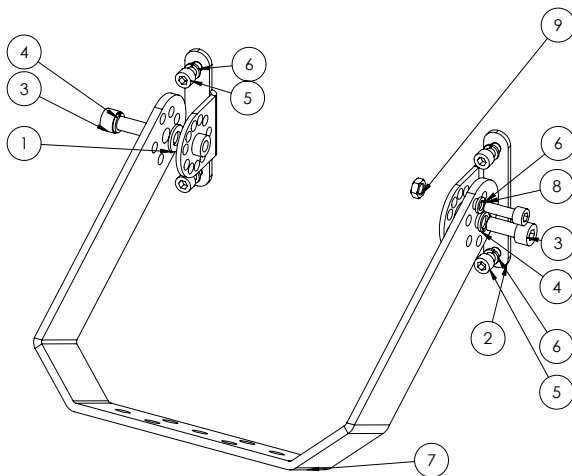

Spartan Bulkhead Standard/Emergency Variant

- The SPARTAN Bulkhead is supplied as standard with the mounting brackets as shown on the above diagram, other mounting methods/brackets available – please contact Raytec.

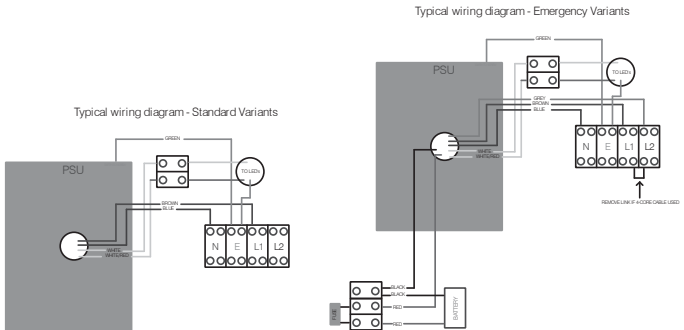

Wire the Mains cable into the terminal block. Provision has been made for this and identified as the E (Earth), L1 (Live switched), L2 (Live permanent) and N (Neutral) terminals. There are two pairs of contacts for each of these to facilitate a mains cable that can be looped in and out of the unit. The L2 terminals on a standard unit are not electrically connected but allows them to be used on the same circuits as *emergency bulkheads*.

- Installer should earth the unit separately – an internal and external earth point are provided as standard
- Connect wires to mains supply.
- If the unit is opened for any reason, disconnect mains – *On emergency luminaires there may be more than one mains supply*
- All SPARTAN bulkheads have terminal blocks suitable for looping 4mm² cable, only one cable should be connected to each terminal block connection

- The battery fuse located within the Bulkhead housing on emergency variants is disconnected after final manufacturing testing. When installing the bulkhead the battery fuse will need to be reconnected and the unit charged for 24 hours and then discharged (repeated 3 times) to bring the battery up to peak capacity. (Unless an 'EMX' intelligent emergency variant – see notes below)*
- If a 4 core cable is used on emergency luminaires – L1, L2, N and E the link cable at the front of the terminal block between L1 and L2 should be removed*
- During emergency operation the light output and duration will be determined by the variant purchased*
- If carrying out Insulation Resistance tests the normal method of insulation testing is to connect Live and Neutral together and test between this point and Earth to prevent the risk of damage to the electronic control gear.

Spartan Intelligent Emergency Operation Guide

Operation

The light fitting will carry out the following function **automatically** after installation:

- Commissioning Cycle
- Function test
- Self-test

A tri-colour LED indicator displays the light fitting status. The indication colours are shown in table 1.

a. Commissioning Cycle

- Starts automatically after 24 hours of uninterrupted charging. If there is a mains failure in this time the count resets for another 24 hours.
- 3 charge/discharge cycles to optimise battery's full capacity.
- Battery is charged for 24 hours before each discharge cycle.
- No need for manual commissioning

b. Function Test

- Carried out every 7 days.
- Checks the function of the battery, lamp and power supply.
- Lasts for few minutes only.

c. Self-test

- Carried out at a random time every 3 months.
- Checks the battery's capacity and lamp's condition.
- Performs self-recovery for the battery if not at peak capacity.
- Is carried out at 100% load
- Discharges only 2/3 of the battery's capacity.

LED indication

LED Indication	Condition
Static Amber	Commissioning in progress
Flashing Amber	Discharge cycle in progress
	LED will flash in relevant colour while discharging
Static Red	Battery defective/Fuse blown
	PSU error
	Battery not at peak capacity
	Light engine failure
No light	Emergency mode activated
Static Green	Commissioning completed

Notes

- The luminaire will switch off momentarily (<0.5sec) during the transition between a test and normal operation.
- If a test was interrupted by a mains failure, the test will be halted, and the unit will enter emergency mode. Once the mains supply is back, the unit will allow 24 hours to recharge the battery before continuing the tests.
- The self-test is carried out at a random time to eliminate the possibility of having more than one unit undergoing the test at the same time.

3. Maintenance

1. It is essential that all SPARTAN Bulkhead units are maintained in accordance with the requirements of the EN60079-17 standard: (Electrical apparatus for explosive gas atmospheres – other than mines).
2. **IMPORTANT.** No modifications are permitted to the unit, all spare parts must be purchased from the manufacturer, unauthorized modifications or spare parts will invalidate certification and make the equipment dangerous.
3. Isolate the SPARTAN Bulkhead from the mains supply and allow to cool before carrying out any maintenance work.
 - For Emergency variants, battery must be isolated/ connected when a hazardous environment is NOT present prior to carrying out any maintenance work.
4. In the unlikely event of a number of LED's failing, the light engine assembly must be replaced. This is achieved by loosening front cover bolts, disconnecting the white LED cables to power supply, remove four M6 bolts from rear of light engine and pull the light engine assembly clear. Re fitting a light engine is a reversal of the above procedure.
5. The unit has one independent power supply, in the event that the power supply needs to be replaced the cables to the LED and mains terminal block will need to be disconnected, the four M6 bolts released, then the power supply can then be removed. Fitting a new power supply is a reversal of the above procedure.
6. Disposal of packaging, SPARTAN unit and old LED assemblies should be carried out in accordance with national regulations.

PROTECTION/CERTIFICATION

CML13ATEX3007, IEC Ex CML14.0001 & CML21UKEX3099

II 2 GD Ex eb mb IIC T4 Gb

Ta -52°C to +55°C (standard variants)

II 2 GD Ex eb mb IIC T4 Gb

Ta -20°C to +46°C (emergency variants)

Ex tb IIIC T98°C Db

IP66 & IP67 Ta = -52°C to +55°C

110V-254V AC or 18-48V AC/18-69V DC

CML 17ATEX4231, IEC Ex CML17.0135 & CML21UKEX4106

II 3 GD Ex ec mc IIC T4 Gc

Ta -50°C to +55°C (standard variants)

II 3 GD Ex ec mc IIC T4 Gc

Ta -20°C to +55°C (emergency variants)

Ex tc IIIC T98°C Dc

IP66 & IP67 Ta = -50°C to +55°C

110V-254V AC or 18-48V AC/18-69V DC

4. Technical Specification

	BL24-STD	BL24-EM
Input Voltage	110-254V AC	
Input Current (230Vac, full load)	0.15A	0.16A
Consumption	20W/34W	24W/37W
Power Factor (230Vac, full load)	>0.97	
Mains Frequency	50/60Hz	
Inrush Current (I_{peak} @50%)	20A, $\Delta t < 300\mu\text{s}$	
Total Harmonic Distortion (230Vac, full load)	<10%	
IP Rating	IP66/67	
Weight (std)	5Kg	6Kg
Dimensions	See previous pages for line diagrams	
ATEX and IECEx and UKEX Rating	See above	

Inrush Current Typical Curve

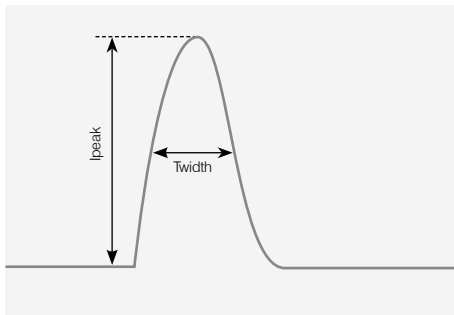

Max number of fittings allowed per MCB
(Based on 230V)

MCB Type	Rating	BL24 - STD	BL24 - EM
B	10A	11	10
B	16A	17	15
B	20A	25	22
B	25A	35	32
C	10A	24	20
C	16A	34	28
C	20A	49	44
C	25A	58	55

Declaration Of Conformity With The Atex Directive 2014/34/EU & UK Directive SI 2016 NO. 1107 (as amended)



Raytec Ltd. declares under our sole responsibility that the product(s) listed below conform with the relevant provisions of the ATEX directive 2014/34/EU of 20th April 2016 and the UK directive SI 2016 No. 1107 (as amended)

Manufacturer	Raytec Ltd Unit 15, Wansbeck Business Park Rotary Parkway Ashington Northumberland NE63 8QW United Kingdom
Description of Equipment	Spartan range of bulkhead luminaires – standard and emergency
Certification Body	CML New Port Road Ellesmere Port CH65 4LZ
Certificate Numbers	Zone 1 - CML13ATEX3007, IEC Ex CML14.0001 & CML21UKEX3099 Zone 2 - CML17ATEX4231, IEC Ex CML17.0135 & CML21UKEX4106 ATEX Quality Assurance Notification CSA BV (2813) UKCA Quality Assurance Notification CSA UK (0518)
Equipment Marking	II 2 GD Ex eb mb IIC T4 Gb Ta -52°C to +55°C (standard variants) II 2 GD Ex eb mb IIC T4 Gb Ta -20°C to +46°C (emergency variants) Ex tb IIIC T98°C Db IP66 & IP67 Ta = -52°C to +55°C 110V-254V AC or 18-48V AC/18-69V DC II 3 GD Ex ec mc IIC T4 Gc Ta -50°C to +55°C (standard variants) II 3 GD Ex ec mc IIC T4 Gc Ta -20°C to +55°C (emergency variants) Ex tc IIIC T98°C Dc IP66 & IP67 Ta = -50°C to +55°C 110V-254V AC or 18-48V AC/18-69V DC

Compliance with the Essential Health and Safety Requirements has been assessed by reference to the following harmonised/designated standards -

EN 60079-0 : 2018

EN 60079-7 : 2015 + A1 : 2018

EN 60079-18 : 2015 + A1 : 2017

EN 60079-31 : 2014

And also 2014/35/EU - Low Voltage Directive, 2014/30/EU - EMC Directive

Signed



Name

Barry Thompson

Position

Director

Dated

Serial number



#05-34, Ubi Techpark (Lobby B), 10 Ubi Crescent, Singapore 408564

Tel. +65 6814 9717 +65 6025 3019

sales@fseprojects.com

www.fsesafe.com / www.fse-exdigital.com

Source: <https://www.rayteclcd.com/>